



WORLD CHARGER

24 VOLT FULLY AUTOMATIC DUAL MODE BATTERY CHARGER

MODEL 16370 TYPE 24EL20-8ET

Specifications

AC Supply:	100-125 or 200-250 volts, 50 or 60 Hertz, single-phase
DC Output:	24 volts, 20 amps
Battery Capacity:	Use only on 24 volt, 12 cell, 180 to 305 ampere-hour (20 hr. rate) liquid electrolyte or sealed "maintenance free" lead-acid batteries

PLEASE SAVE THESE IMPORTANT SAFETY AND OPERATING INSTRUCTIONS

For correct operation of the equipment, it is important to read and be familiar with this entire manual before installing and operating the charger.
DO NOT DISCARD THIS MANUAL AFTER READING.



LOOK FOR THIS SYMBOL TO POINT OUT SAFETY PRECAUTIONS. IT MEANS: *BECOME ALERT—YOUR SAFETY IS INVOLVED.* IF YOU DO NOT FOLLOW THESE SAFETY INSTRUCTIONS, INJURY OR PROPERTY DAMAGE CAN OCCUR.

INTRODUCTION

This battery charger provides superior battery performance and life, with low electrical power consumption. The solid state design provides a highly reliable, self-regulating charger with a minimum of moving parts, designed for long, trouble-free service. The Dual-Mode design allows the charger to be used on either liquid electrolyte or sealed "maintenance-free" lead-acid batteries. Simply set the battery mode switch to the type of battery being charged and the charger output is automatically adjusted to the proper level. When the battery has reached its maximum state of charge, the solid state control turns the charger off.

INITIAL INSTALLATION

This charger is equipped with an input AC voltage select switch located on the front of the charger. Properly setting the switch allows the charger to operate from either 100 to 125 volt or 200 to 250 volt single phase, 50 or 60 Hertz outlets. Set the input AC voltage select switch to 115 for a measured input voltage of 100 to 125 VAC, or 230 for a measured input voltage of 200 to 250 VAC.

The charger battery mode switch must be set correctly to charge either wet, or sealed, including gel cell, lead-acid batteries. Sliding the switch to gel, sealed or maintenance free charges the battery to a maximum of 2.38 volts per cell. The liquid or wet setting allows the battery to charge to 2.5 to 2.6 volts per cell.

⚠ CAUTION: BE SURE BOTH THE AC VOLTAGE SELECTOR SWITCH AND THE BATTERY MODE SWITCH ARE PROPERLY SET BEFORE USING THE CHARGER. CHARGER MAY BE DAMAGED, OR BATTERY MAY BURST CAUSING PERSONAL INJURY IF SWITCHES ARE NOT SET PROPERLY.

Locate the charger in an accessible spot where the AC supply cord can be easily reached. Provide adequate ventilation for the charger. The convection cooled design requires an unobstructed flow of cooling air for proper operation. Keep all charger ventilation openings at least two inches (2") (5cm) away from all other objects. DO NOT allow clothing, blankets, or other material to cover charger.

⚠ WARNING: TO REDUCE THE RISK OF FIRE, DO NOT USE CHARGER NEAR FLAMMABLE MATERIALS OR VAPORS.

⚠ DANGER: RISK OF ELECTRIC SHOCK! CONNECT AC SUPPLY CORD DIRECTLY TO GROUNDED, 3-WIRE OUTLET. DO NOT TOUCH UNINSULATED PORTION OF DC OUTPUT TERMINALS OR BATTERY TERMINALS. DO NOT EXPOSE CHARGER TO RAIN OR POWER WASH. REPLACE DEFECTIVE CORDS, WIRES OR CONNECTORS IMMEDIATELY.

Do not operate this charger if it has received a sharp blow, was dropped, pulled off a shelf, or otherwise damaged in any manner. Refer to a qualified service agent.

EXTENSION CORD REQUIREMENTS

Always use a three-conductor, No. 14 AWG (1.5mm) Heavy Duty cord with ground, properly wired, in good electrical condition and keep it as short as possible. Make sure the pins on the plug of the extension cord are the same number, size and shape as the AC plug of the battery charger. The use of an improper extension cord could result in a risk of fire or electric shock. Locate all cords so they will not be stepped on, tripped over or otherwise subjected to damage or stress.

GROUNDING INSTRUCTIONS

This battery charger must be grounded to reduce the risk of electric shock. This charger is equipped with an AC supply cord having an equipment-grounding conductor which must be connected to the ground prong of an appropriate plug for the AC voltage being used. This plug must be connected to an appropriate AC outlet which is properly installed and grounded in accordance with the National Electrical Code (U.S.) and all local codes and ordinances.

⚠ DANGER: IMPROPER CONNECTION OF THE EQUIPMENT-GROUNDING CONDUCTOR CAN RESULT IN A RISK OF AN ELECTRIC SHOCK.

The conductor with insulation having an outer surface which is green, with or without yellow stripe(s), is the equipment-grounding conductor. Do not connect the equipment grounding conductor to a live terminal. If the supply cord of this equipment is damaged, it must be replaced with an original equipment manufacturer supplied cord or other approved cord by a qualified/licensed person.

NORMAL OPERATION - STATIONARY OR SHELF USE

Refer to the instructions on the charger before each use.

1. Connect input cord to properly grounded supply outlet that matches the AC voltage select switch setting. Set power switch to "AUTO, (I)" for charger to operate.
2. Connect the output charging plug to the correct battery system as specified. Ensure the battery mode switch is set correctly for the type of lead-acid battery to be charged.
3. The charger will start after a short delay, "CHARGING" light will glow, transformer hum, and ammeter indicate initial charge rate.

⚠ WARNING: LEAD-ACID BATTERIES GENERATE GASES WHICH CAN BE EXPLOSIVE. CHARGE ONLY IN WELL VENTILATED AREAS. DO NOT DISCONNECT CHARGER DC OUTPUT TERMINALS FROM BATTERY WHEN CHARGER IS ON. THE RESULTING ARCING AND BURNING COULD CAUSE THE BATTERY TO EXPLODE. KEEP SPARKS, FLAME AND SMOKING MATERIALS AWAY FROM BATTERY.

If the charger must be stopped, disconnect the AC supply cord from outlet.

4. Monitor the ammeter for correct charge rate. The initial charge rate should be approximately 20 amps. If the battery has not been discharged, or the AC supply voltage is lower than 100/200 volts, the initial charge rate may be less than 20 amps.

The charge rate will decrease as the battery reaches full charge. On a liquid electrolyte battery, the charge rate will decrease to about 8 amps and remain there until the charger turns off. As the battery ages, the charge rate may no longer decrease to the 8 amp finish rate. This is normal and the charger will still determine when the battery is charged to its optimum and then turn off.

When charging a sealed "maintenance free" battery, the charge rate will decrease to less than 1 amp and remain there until the charger turns off. An older battery, even though it is properly charged, will gradually lose capacity and should be replaced when it will no longer perform as required.

5. Charger turns off automatically when battery is fully charged. Charge time varies with battery size and depth of discharge. Allow 12 hours for normal charging. Severely discharged batteries may require up to 18 hours to be properly charged and equalized. After the charger has turned off, disconnect the AC supply cord from outlet.
6. Charger turns off after 18 hours if unable to charge battery and "BATTERY FAULT" light glows. See Troubleshooting.

PROPER CARE OF DEEP-CYCLE BATTERIES

Batteries are subject to severe deep-cycle duty on a daily basis. For this reason, it is important that only deep-cycle batteries be used. Although these batteries are designed to withstand such duty, the following precautions must be observed to obtain good performance and maximum cycle life.

1. Always observe the following personal safety precautions when working with lead-acid batteries:
 - a. Someone should be within range of your voice or close enough to come to your aid when you work near a battery.
 - b. Have plenty of fresh water and soap nearby in case battery acid contacts skin, clothing or eyes.
 - c. Wear complete eye protection and clothing protection. Avoid touching eyes while working near battery.
 - d. If battery acid contacts skin or clothing, wash immediately with soap and water. If acid enters eye, immediately flood eye with running cold water for at least 10 minutes and get medical attention immediately.
 - e. NEVER smoke or allow a spark or flame in vicinity of batteries.
 - f. Be extra cautious to reduce risk of dropping a metal tool onto battery. It might spark or short-circuit battery or other electrical part that may cause explosion.
 - g. Remove personal metal items such as rings, bracelets, necklaces and watches when working with a lead-acid battery. A lead-acid battery can produce a short-circuit current high enough to weld a ring or the like to metal, causing a severe burn.

- h. NEVER charge a frozen battery.

⚠ DANGER: TO REDUCE RISK OF ELECTRIC SHOCK, ALWAYS DISCONNECT THE AC SUPPLY CORD FROM ITS OUTLET AND THE DC OUTPUT CORD FROM THE BATTERY BEFORE ATTEMPTING ANY MAINTENANCE OR CLEANING OF THE BATTERY.

2. New batteries should be given a full charge before their first use because it is difficult to know how long batteries have been stored.
3. Limit use of new batteries for first 5 cycles. New batteries are not capable of their rated output until they have been discharged a number of times.
4. Do not excessively discharge batteries. Excessive discharge can cause polarity reversal of individual cells resulting in complete failure shortly thereafter.

Limited use of new batteries will minimize the chance of cell reversal.

5. CHECK THE LEVEL OF THE ELECTROLYTE IN CONVENTIONAL LIQUID ELECTROLYTE ACID BATTERIES MONTHLY. MAINTAIN THE PROPER ELECTROLYTE LEVEL BY ADDING DISTILLED OR PURIFIED WATER WHEN NECESSARY. Electrolyte levels lower during discharge and rise during charge. Therefore, it is mandatory that water be added to cells ONLY when they are fully charged; do not overfill. Old batteries require more frequent additions of water than do new batteries.
6. Keep tops of batteries clean and dry to prevent excessive self-discharge. Keep battery terminals reasonably tight.

TROUBLESHOOTING

⚠ CAUTION: DO NOT OPERATE THE CHARGER IF IT IS DAMAGED OR APPEARS TO BE MALFUNCTIONING. PERSONAL INJURY OR DAMAGE TO THE CHARGER OR BATTERIES MAY RESULT. DO NOT DISASSEMBLE THE CHARGER. TAKE IT TO A QUALIFIED SERVICE AGENT WHEN SERVICE OR REPAIR IS REQUIRED. INCORRECT REASSEMBLY MAY RESULT IN RISK OF ELECTRIC SHOCK OR FIRE.

1. If the charger does not turn on, check for one of the following:
 - a. Charger is not plugged into a live AC outlet.
 - b. Battery connections are wrong (reverse polarity).
 - c. Battery is no longer serviceable (voltage below 4 volts for 24 volt system).

2. If the charger turns off before the batteries are fully charged, it indicates one of the following:
 - a. The AC power was interrupted during charge.
 - b. The DC cord was accidentally disconnected from the battery during charge.
 - c. The battery has been allowed to sulfate. Charge the battery at least once every three days when the equipment is lightly utilized. Once sulfation is allowed to take place, it may be partially reduced by returning, temporarily, to daily charging.
3. A decrease in equipment range where the battery loses power earlier and earlier in the day indicates one of the following:
 - a. The electrolyte level in conventional liquid electrolyte lead-acid batteries was allowed to drop below the top of the battery plates. Add distilled water to just cover the top of the plates immediately upon discovery and fill to the proper level with distilled water at the completion of the very next charge cycle.

Battery capacity lost in this manner is permanent and is not recovered with additional charge cycles.
4. The charger runs 18 hours before turning off. This indicates one of the following:
 - a. Batteries larger than 305 amp-hour capacity (20 hr. rate) can require more than 18 hours to charge.
 - b. New batteries (5 cycles or less) can require more than 18 hours to charge.
 - c. Overdischarged batteries can require more than 18 hours to charge.

WIRING DIAGRAM

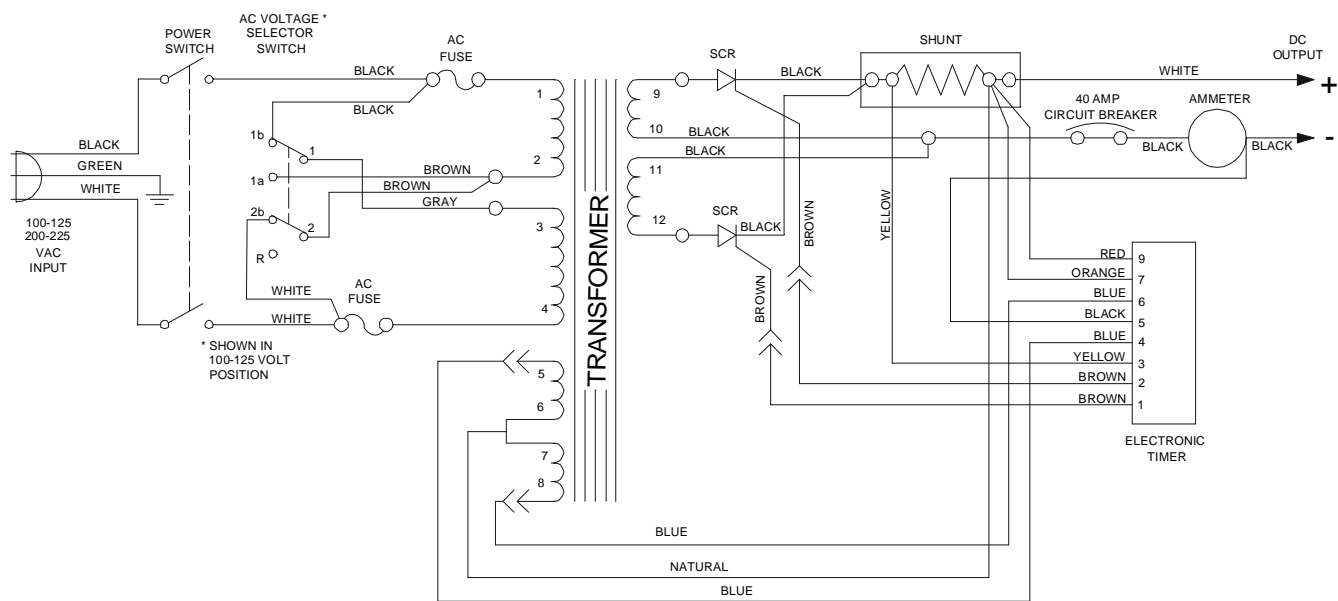

L2115S49

PARTS LIST FOR DUAL MODE BATTERY CHARGER MODEL 16370 TYPE 24EL20-8ET 100-125 OR 200-250 VAC / 50-60 HZ

PART NO.	QTY.	DESCRIPTION
20933S	1	CASE ASSEMBLY
16375S	1	TRANSFORMER ASSEMBLY
16369S	1	AMMETER
20919S	2	HEATSINK ASSEMBLY, W/ SCR
23224S	2	SCR ASSEMBLY
16450S	1	ELECTRONIC TIMER ASSEMBLY
19233S	1	CONTROL CABLE ASSEMBLY
02028S	1	BUSHING, INSULATOR, 7W-2, FOR DC CORDSET
03894S	1	BUSHING, INSULATOR, 7K-2, FOR AC CORDSET
20916S	1	CORDSET, AC, 16/3, 80", MOLDED PLUG
33016S	1	CORDSET, AC, 14/3, 248", MOLDED PLUG
20924S	1	CORDSET, DC, 12/2, 108", SB50 PLUG, GRAY
20914S	1	CORDSET, DC, 12/2, 108", SB50 PLUG, RED
20926S	1	CORDSET, DC, 12/2, 108", SB175 PLUG, RED
34146S	1	CORDSET, DC, 12/2, 108", SY120 PLUG, GRAY
21408S	1	CORDSET, DC, 12/2, 108", NO PLUG
05322S	2	FUSEHOLDER
19623S	2	FUSE, 8 AMP, MDA-8
20917S	1	SWITCH ASSEMBLY
18696S	1	SHUNT, ELECTRONIC
14092S	1	CIRCUIT BREAKER, 40 AMP
29028S	1	CORDSET, AC, 1.0 mm/3, 98", CEE 7/7 PLUG
28843S	1	CORDSET, AC, 1.5 mm/3, 80", NO PLUG

LIMITED WARRANTY

Lester Electrical warrants each new Lester Battery Charger for defects in material and workmanship for a period of two (2) years from the date of manufacture of the complete unit. Repairs can be made at the Lester factory. To do so, first obtain a "Return Material Authorization" number by calling the Service Department of Lester Electrical (402 477-8988) or by e-mailing service@lesterelectrical.com and send the defective unit with transportation charges prepaid to:

Lester Electrical
625 West A Street
Lincoln, NE 68522-1794 USA
Attention: Service Department
RMA # _____

If the unit or parts are found in the reasonable judgment of Lester to be defective in material or workmanship, repair or replacement will be made by Lester without charge for parts or labor. Repair or replacement will be at the discretion of Lester, with replacements being made using current models or parts performing the equivalent function. Labor charges other than those incurred at the Lester factory are not covered under this warranty. All expenses associated with delivering defective items to the Lester factory and the expense of returning repaired or replaced items from the Lester factory to the owner will be paid for by the owner. All warranty work accomplished at the Lester factory will be completed with a reasonable time after receipt of defective items.

This warranty does not cover any semiconductor parts, such as diodes, which are vulnerable to electrical overloads beyond the control of Lester. Warranty on parts not manufactured by Lester, which include, but are not limited to, timers and ammeters, is limited to the period specified in the original manufacturer's warranty.

This warranty does not cover any charger that has been subject to misuse, neglect, negligence, or accident, or operated in any way contrary to instructions specified on the charger case and in the owner's manual. No claim of breach of warranty shall be cause for cancellation of the contract of sale of any Lester charger. Lester assumes no responsibility for loss of time, inconvenience, or other damage, consequential or otherwise, resulting from a defective charger. All implied warranties (including merchantability) are limited in duration to the two years from date of manufacture warranty period.

Some states do not allow the exclusion or limitation of incidental or consequential damages; or limitations on how long an implied warranty lasts, so the above limitations may not apply to you. This warranty gives you specific legal rights, and you may also have other rights which vary from state to state.

Lester's obligation under this warranty is strictly and exclusively limited to the repair or replacement of defective items. Lester issues this warranty in good faith and with full confidence in the workmanship and quality of Lester products.